

Tiama HOT form

Glass distribution monitoring



Features

Infrared radiation measurements

The Tiama HOT form captures infrared glass emission with an infrared camera to give information on container glass distribution and anticipate the creation of defects.

Statistical data on the production

The system is able to deliver statistical data on the production to improve process management. Thanks to the IS synchronization, data are linked to sections and cavities.

Equipped with infrared cameras (one or two), the Tiama HOT form analyzes glass distribution by measuring radiation levels of articles.

User interface



Customers benefits

■ **Anticipation of IS machine issues** such as sectional cooling imbalances or poor loading

■ **Global and specific statistics to help for process control**

■ **Limited footprint of the line:** the system is directly fixed on the conveyor

■ **Immediate feedback** on the process, no need to wait for Cold End

■ **Greater awareness** of glass distribution issues

■ **Tiama service:** benefit from our worldwide presence and our whole range of services

Operating principle

The Tiama HOT form is composed of one (or two, optional) infrared camera, located inside one (or two) metallic tube, directly fixed on the conveyor. The tubes are shared with the Tiama HOT eye, so if a Tiama HOT eye is already installed on the line, the Tiama HOT form camera will be installed inside the same tube.

The Tiama HOT form takes images of articles on the conveyor and measures their radiations.

The system is synchronized with the IS machine, so that the images of articles taken by the Tiama HOT form are linked to their section and cavity of origin.

The electronic of the system is located in the Tiama HOT systems electrical cabinet, shared with the other Tiama HOT systems module (one common cabinet for all modules of one line).

Installation requirements

Tiama HOT systems electrical cabinet
(common to the whole Tiama HOT systems range)

Width 600mm
Depth 1 050mm
Height 1 400mm

Air requirements:
Pressure: 4 bars

Article dimensions:
Height: from 20mm to 350mm
Diameter: from 20mm to 160mm

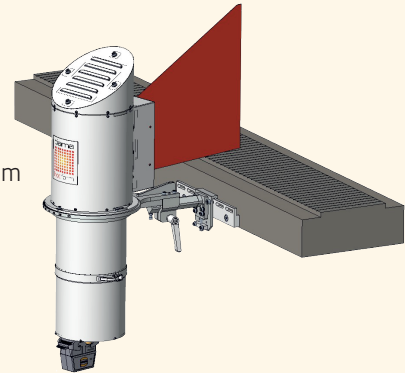

the Smart Factory concept

The Tiama HOT form is a monitoring solution to help customers to improve the management of their process and to reach their quality level. The Tiama HOT form belongs to the Tiama HOT systems range, a complete set of modules which gives key information on the process from the gob to the formed articles. The Tiama HOT form is also part of the smart factory concept developed by Tiama, the system provides a full range of data which can be used in order to have a global overview of the plant, from the Hot End to the Cold End.

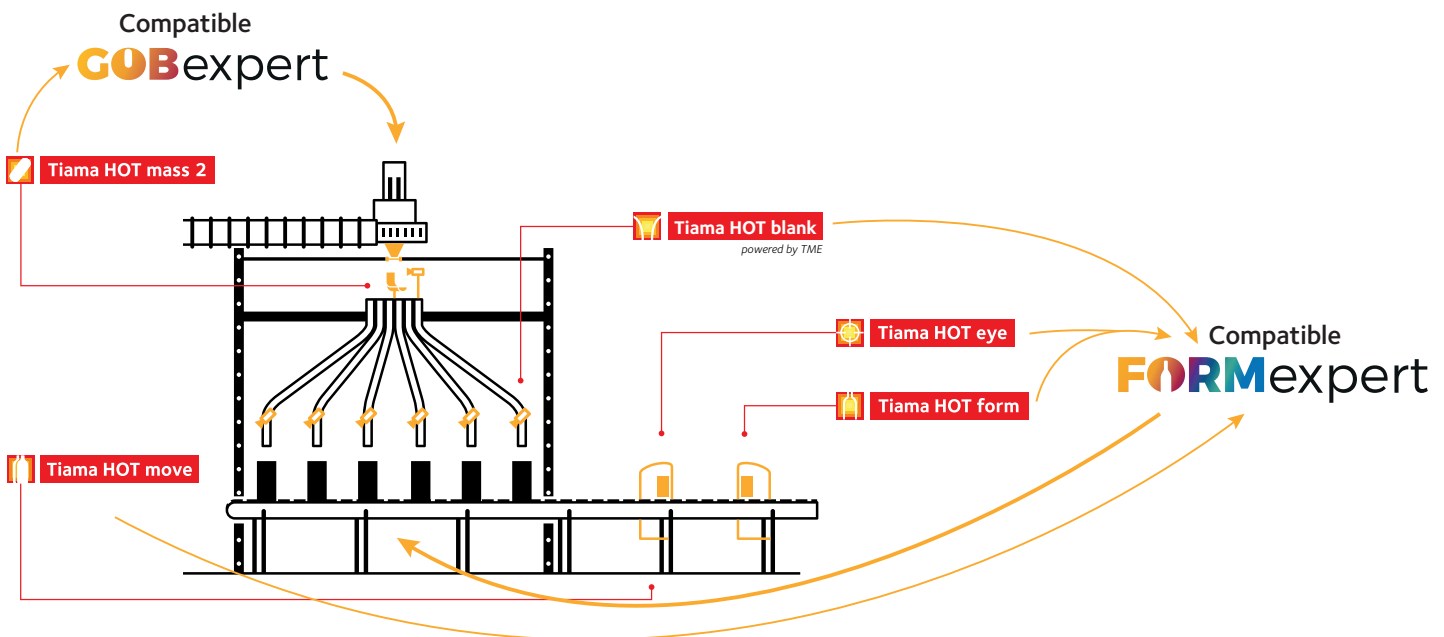

Contact us

Headquarters: TIAMA
215 Chemin du Grand Revoyet
69230 Saint-Genis-Laval
France

www.tiama.com
marketing@tiama.com
+33 4 37 20 15 65

